



S I E R R A
RS500
C O S W O R T H



Ford and Cosworth have been synonymous with success since 1959, when the 105E Anglia engine was tuned for Formula Junior racing. Eight years later, the Ford-Cosworth DFV made its debut in the Dutch Grand Prix, where the 3-litre V8 powered Jim Clark and his Lotus 49 to victory. The engine went on to win a record-breaking 155 world championship races.

Turbocharged 2.65-litre versions of the DFV have won the Indianapolis 500, the USA's toughest race, every year since 1978.

Cosworth engines based on the Ford Cortina's cylinder block dominated international Formula Two racing in 1964-65 and 1967-71. The BDA power unit made the Escort a world-beating rally car. Today, Ford-Cosworths power the Grand

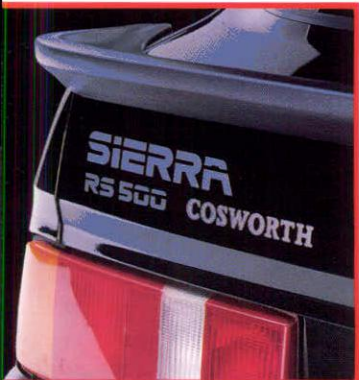

The eye-catching rear wing and tailgate spoiler are features developed to provide increased downforce and stability at racing speeds, and sit well above the discreet Sierra RS 500 Cosworth badging.

SIERRA RS 500 COSWORTH

Prix contenders built by Benetton, Tyrrell, March, Lola and AGS.

Now comes the Sierra RS 500 Cosworth. This sensational saloon's turbocharged 2-litre engine develops 224 PS in road-going form — and around a mighty 450 PS when fully tuned for Group A racing.

Evolved from the Sierra RS Cosworth, the RS 500 has a body as dramatic and efficient

as its powertrain. The front 'skirt' has been modified to increase airflow through the engine compartment at racing speeds. Aerodynamic stability is enhanced by fitting a 'fence' to the rear wing, which is supplemented by a tailgate spoiler. Wheel arches flared to take 205/50VR15 tyres flow into extended rocker panels.

Other features include high-tech polycarbonate bumpers,

electrically operated and heated door mirrors, central locking, tinted glass, and alloy wheels.

Ford is building 500 examples of this very special and exclusive Sierra.



SIERRA RS 500 COSWORTH



Recaro seats, fully adjustable and trimmed with 'Roma' cloth provide the lateral support when cornering at speed while maintaining the high degree of comfort required by today's drivers.

The bank of rocker switches to the right of the steering wheel includes a rocker switch for fog lights which are an option fitted at extra cost.



Ford's new Sierra RS 500 Cosworth combines race-winning power with equally high levels of comfort, convenience and refinement. Like the rest of the class-leading Sierra range, this high-performance hatchback is a spacious versatile and well-equipped car with plenty of room for five people, plus all the luggage needed for a family holiday.

The cockpit features superb, cloth-trimmed Recaro seats carefully shaped to provide support all the way from thighs to shoulders. Cornering forces are absorbed by their padded, wrap-round sides. Both have fully adjustable head restraints, and the driver's seat is adjustable for height, as well as rake and reach.

Neat instruments supplemented by warning



lights are clearly visible through the padded, sports-type steering wheel. Minor controls include a quartet of micro switches to the right of the wheel, and, to the left, smooth-sliding levers for the sophisticated heating and ventilation system. Ford's applied ergonomics make everything easy to see, identify and operate.

The swiftest and most stylish

Sierra's other attractions include door bins and map pockets, a tilt-or-slide glass sunroof, a leather-trimmed gear lever knob, electrically operated front windows, cloth-trimmed door panel inserts, adjustable instrument panel lighting, and an overhead console with a convenient map-reading light. In-car entertainment is provided by Ford's top-quality Electronic

Sound System (ECU2) which includes a power amplifier and an electrically operated radio aerial.

Ford's Sierra RS 500 Cosworth is the high-performance hatchback that looks after its driver *and* its passengers.

The new Sierra RS has one of the most remarkable engines ever produced by the phenomenally successful Ford-Cosworth partnership. In standard form it develops 224 PS and proved capable of rocketing the three-door hatchback from zero to 60 mph in just 6.2 seconds† when tested on Ford's proving ground. Power soars to an astonishing 450 PS when the turbocharged 2-litre is fully tuned for the race track, where the Sierra RS Cosworth will contest the European and World Touring Car Championships.

Based on a production Ford cylinder block, the four-cylinder engine has an extremely efficient light-alloy head. Twin overhead camshafts, driven by a toothed belt of rubber reinforced with glassfibre, operate four valves per cylinder. The head is cast by a process that avoids the risk of contamination by drawing alloy straight from furnace to mould. There is no contact with the air until the metal has solidified.

Power is boosted by a Garrett AiResearch turbocharger with an air-to-air intercooler. Multi-point fuel injection and electronic ignition are controlled by a very advanced engine management system. So is the wastegate, which acts as a safety valve for the turbocharger. Peak efficiency is maintained by sensors that refer vital information to a 'map' in the system's computerised memory.

Features engineered to combat high operating temperatures include sodium-filled exhaust valves, and oil jets directed at the underside of the forged aluminium

pistons. The piston crowns have a shallow bowl shaped to create the carefully controlled 'squish' combustion characteristics essential for low exhaust emissions and good economy.

Forged, heat-treated connecting rods join the pistons to an extremely robust, forged-steel crankshaft with five main bearings. At the bottom of the engine, a die-cast aluminium sump saves weight and also improves oil cooling. There are nine flywheel attachment bolts, instead of the six used on other Sierras, and power is fed to the five-speed gearbox through a special heavy-duty clutch.

The front suspension has MacPherson struts, lower track control arms, coil springs, anti-roll bar and gas-filled dampers.

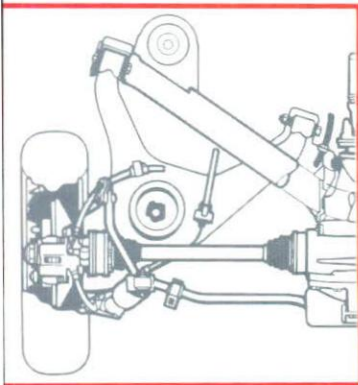
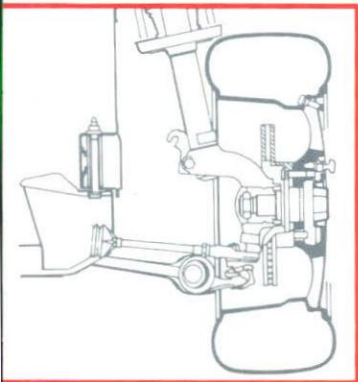

The rear suspension has semi-trailing arms, coil springs, anti-roll bar and gas-filled dampers.

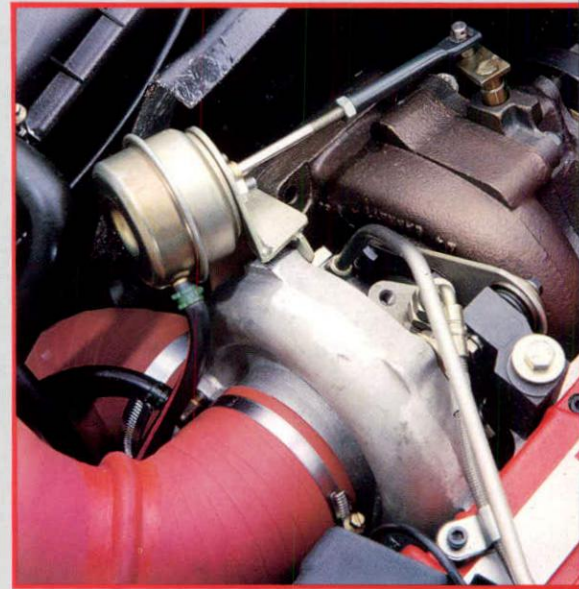

The engine's inherent efficiency is boosted by a Garrett AiResearch T31/T04 turbocharger that is mounted onto a special four branch high nickel-alloy manifold. The turbocharger is water cooled to protect the turbo shaft bearings and is set to generate as much low-speed torque as possible.

†Ford test figures.

SIERRA RS 500 COSWORTH

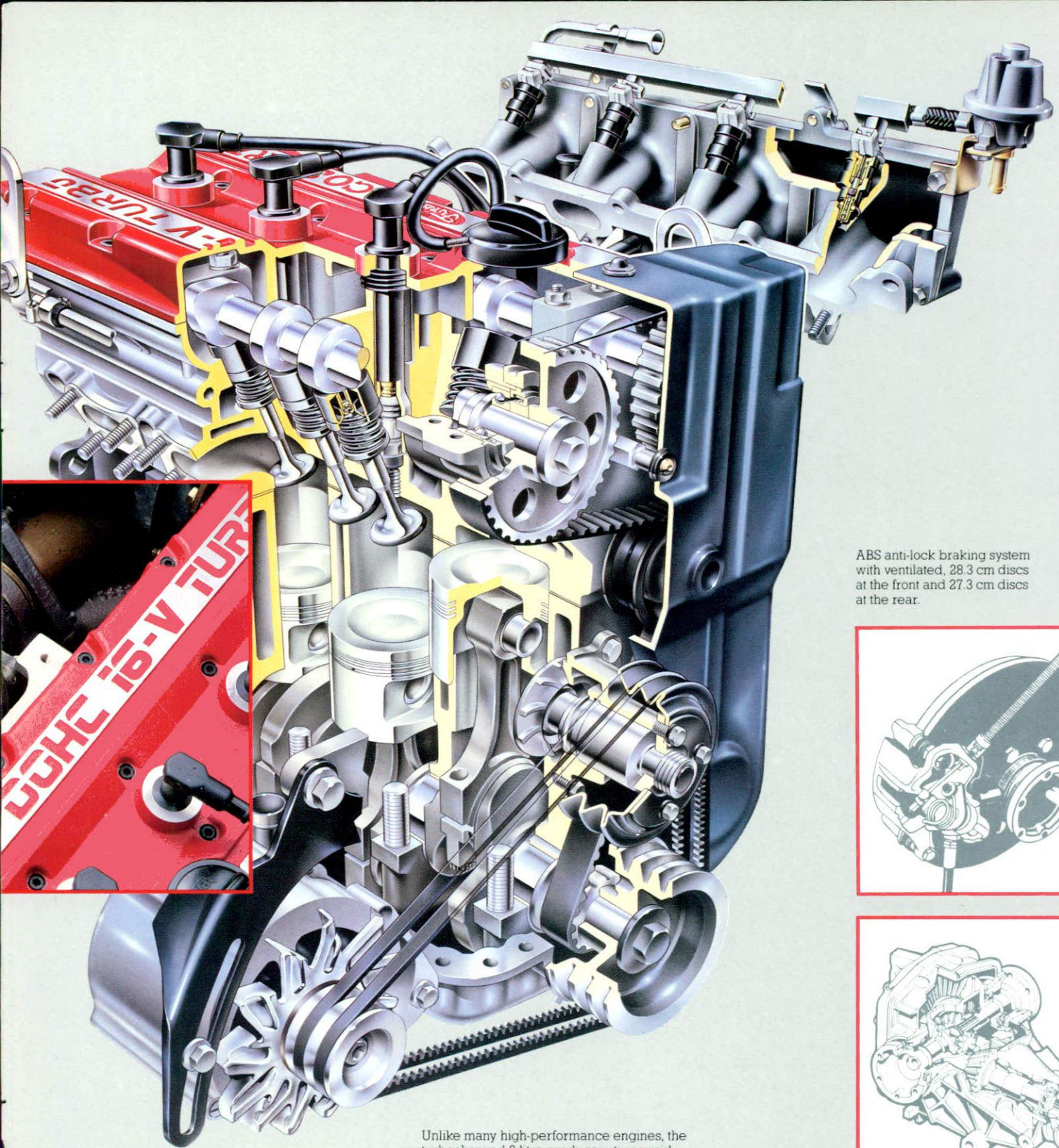

ABS anti-lock braking system with ventilated, 28.3 cm discs at the front and 27.3 cm discs at the rear.

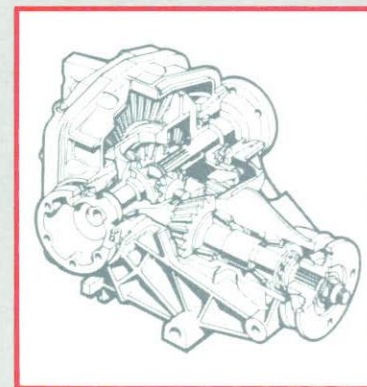
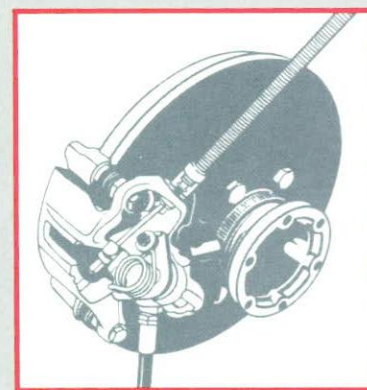

Unlike many high-performance engines, the turbocharged 2-litre produces strong mid-range torque. It is equally at home on road or track.

Limited-slip differential with viscous coupling eliminates 'snatch'.

SPECIFICATIONS

ENGINE	2.0 DOHC fuel injected with Garrett AiResearch T31/T04 turbocharger and intercooler
Capacity cc	1993
Cylinders	4 in-line
Bore (mm)	90.8
Stroke (mm)	76.95
Compression ratio	8.0:1
Fuel induction	Weber/Marelli multi-point fuel injection and electronic management system and Garrett AiResearch T31/T04 turbocharger
Choke	Automatic
Ignition	Electronic breakerless
Max. power DIN KW (PS) at rpm	164 (224)/6000
Max. torque DIN Nm at rpm	280/4500
Block	Cast iron
Head	Aluminium
Cooling	Water
Bearings	5 main
Valve gear	DoHC, four valves per cylinder, toothed drive belt

PERFORMANCE Ford test figures

MANUAL 5 SPEED	
Max. speed (mph)	153
0-60 mph (secs.)	6.2

TRANSMISSION

Gearbox	Five-speed manual
Internal ratios	
Top	0.80:1
4th	1.00:1
3rd	1.34:1
2nd	1.94:1
1st	2.95:1
Final drive ratio	3.64:1

FUEL CONSUMPTION

All figures in mpg (L/100 km) are from officially approved tests under the Passenger Car Fuel Consumption Order 1983.

MANUAL 5 SPEED	
Constant driving speed 56 mph (90 kmh)	33.0 (8.6)
Constant driving speed 75 mph (120 kmh)	24.5 (11.5)
Simulated urban driving	20.6 (13.7)

AERODYNAMICS

Coefficient Cd	0.36
----------------	------

SUSPENSION

Front	MacPherson Struts, lower track control arms, coil springs, anti-roll bar, gas-filled dampers
Rear	Semi-trailing arms, coil springs, anti-roll bar, gas-filled dampers

STEERING

Type	Rack and pinion
Assistance	Power, variable rate

BRAKES

Front	Ventilated discs, 28.3 cm. diameter
Rear	Discs, 27.3 cm. diameter
Assistance	Hydraulically boosted
Circuit	Diagonally split, ABS anti-lock brake system

WEIGHTS (kg) (nominal)

Gross vehicle weight	1700
Kerbweight	1240
Max. roof rack load	75

STANDARD FEATURES

ENGINEERING

- Body, three-door saloon
- Engine, 2.0 DOHC fuel injected with Garrett AiResearch T31/T04 turbocharger and intercooler
- Gearbox, five-speed with viscous coupled limited slip differential
- Choke, automatic
- Tyre size, 205/50 VR x 15

STANDARD FEATURES

EXTERIOR

- Bodyside moulding, black
- Central locking with torch-key
- Door mirrors: Body coloured housing Electrically operated and heated
- Fuel tank cap, body-coloured and locking by ignition key
- Grille, single slot with additional cooling vents in bonnet
- Handles/locks, black
- Hazard warning flashers
- Heated rear window
- Horn, dual-tone
- Hydraulically boosted, anti-lock, all round disc brakes
- Lamps: Halogen headlamps Integral front driving lamps Reversing lamps Rear fog lamps
- Power-assisted steering, variable rate
- Rocker panel mouldings, body-coloured
- Side repeat indicators
- Spoilers: Driver wiper arm Front integral Tailgate, body-coloured single plane with trailing edge fence Lower tailgate mounted spoiler
- Tailgate push lock release and handle
- Tailgate wash/wipe
- Tinted glass all round
- Tow hooks, front and rear
- Wheels, 7" x 15" alloy
- Windscreen, laminated
- Windscreen wash, electric
- Windscreen wipers: Two-speed Variable intermittent

INTERIOR

- Carpet, load compartment
- Carpet, passenger compartment and front door bins
- Centre console, extended
- Cigar lighter, front illuminated
- Clock, quartz digital solid-state
- Cloth door inserts
- Courtesy lights: Front Tailgate load compartment
- Fascia instrument switches, illuminated
- Fascia light dimmer
- Gas struts on tailgate
- Gearknob, leather covered
- Glove box with lid and illumination
- Glove box/armrest, front centre with cassette storage, cloth covered
- Headlining, Beaumont cloth
- Head restraints on front seats, fully adjustable
- Heater: Fan, three-speed Illuminated controls
- In-car entertainment: Aerial, electrically operated Four speakers Electronic sound system ECU2 including power amplifier

STANDARD FEATURES

INTERIOR continued

- Map light in overhead console
- Package tray, rear, tilting/removable
- Rear view mirror, dipping
- Seats: Driver height adjustment Fabric trim, 'Roma' Front reclining, sports Recaro Map pockets in seat backs 60/40 split rear back rest and seat cushion
- Seat belts: Front, inertia reel Rear, two lap/diagonal inertia reel and one lap centre static
- Steering wheel, leather covered three-spoke sports with centre horn push
- Stowage bins in front doors
- Stowage shelf, driver lower
- Sunroof, tilting/sliding glass
- Tachometer with turbo boost gauge
- Trip recorder
- Vanity mirror on passenger survivor
- Warning lights: Anti-lock brake system failure Brake failure/handbrake 'Clean hands' Direction indicator Graphic warning module Ignition/alternator Main beam Oil pressure
- Windows, electrically operated front

COLOUR AND MAIN PATTERNED TRIM

SOLID COLOUR	'Roma'
Black	Grey

ILLUSTRATIONS, DESCRIPTIONS AND SPECIFICATIONS

Ford policy is one of continuous product development. The right is reserved to change specifications, colours and prices of the models and items illustrated and described in this publication at any time. Where possible, any such changes which may be introduced after publication of this booklet but before it is supplied will be incorporated herein or announced by means of a notice prominently displayed in Ford Dealerships at the point of supply. For the latest details always consult your Ford Dealer.

Published by Marketing Programmes, Ford Motor Company Limited, Brentwood, Essex, England. FA 815 / July 1987.

Designed and produced by Allan Burrows Limited Ingatestone, Essex.

Printed in England by White Dove Press Limited.

